

Fundamentals of Nutrient Management: Why Nutrient Replacement is Essential in Organic and all Agriculture

1. Introduction

There is a belief, going back to the foundation of organic agriculture, that nutrient replacement, i.e., the use of 'fertilisers', within organic agriculture is not required. Scientific theories and laws as well as practical farming evidence, now conclusively shows that this belief is incorrect, and nutrient replacement / cycling is essential for all forms of agriculture including organic. This paper is an explanation of why nutrient replacement / cycling is essential, starting at the most fundamental levels of the physical laws of nature, progressively building a holistic / systems based view of the behaviour of nutrients, and also energy, in farm systems and the biosphere as a whole. While such a view may at first appear overly detailed, even irrelevant to agriculture, one of the primary keys to the success of scientific understanding is the ability to create a theoretical understanding with precise predictive power. Much of agriculture is based in the complex sciences of biology and ecology where random processes prevent theoretical explanation and prediction i.e., much of agricultural science is empirical. Nutrient management is one of the few areas of agriculture where fundamental physics, even at the sub-atomic level, can penetrate right through the noise of biological systems to directly inform the actions of farmers. Empowered by such understanding farmers have the ability to fully understand the fundamentals of nutrient management and make better informed decisions about their own practices. Such a holistic perspective also 'shines a light' on the unsustainability of nutrient management in 'industrial' agriculture and the wider human societies of which it is the foundation, as well as reiterating the solutions that have been known for two centuries.

1.1 History and the Schism

The 'schism' within organic agriculture regarding nutrient management goes back to its founders. This debate and argument extended over a considerable period of time and has never been fully concluded, with different parts of the organic movement retaining conflicting views to this day. Two sides of the debate can be described by the two terms 'The Law of Return' and 'Closed System'. The former was originally promoted by Sir Albert Howard, indeed the very phrase 'The Law of Return' is now intimately associated with his name. The latter was the position Lady Eve Balfour eventually adopted and is continued to this day by her philosophical descendents such as the Soil Association. There were many others involved on both sides of the debate, with some taking significant time to decide where they stood and/or changing sides. However, I have chosen Howard and Balfour to represent the two sides, as they are among the most pivotal founders of organic agriculture, are still very widely known, and therefore best illustrate how profound this split was, and therefore deserving of the title 'Schism'.

Concisely defining the two sides is not straight forward as the issue of nutrient management is invariably tied up in the wider issue of soil health and its effects on the ecological food chain extending through plants to animals including humankind. The descriptions of the Law of Return and the Closed system given here therefore have to leave out the details, but due to our understanding of the nature of nutrients from the sub-atomic to the system level there are no 'devils in the details', i.e., the system as a whole is linear, rather than non-linear and therefore predictable rather than unpredictable.

The Law of Return is defined by Howard in "An Agricultural Testament" (1943) where he says that it is essential to "...adopt farming practices that would follow nature's example of recycling all natural and organic waste products back to the soil" and "When man converts land to agriculture and harvests crops and livestock from the fields, mineral nutrients are removed from the soil. The failure of man to effectively return the waste products of agriculture back to the land results in mineral depletion of soil and represents a lost opportunity to build soil humus." At first blush, these descriptions could well describe a closed system, however, the position adopted by Balfour and the Closed System proponents is critically different. The Law of Return states that all mineral nutrients removed from a farm, in whatever form,

must be returned back to the farm if mineral depletion (soil mining) is to be prevented. Balfour's position was that the amounts of nutrients removed in farm produce are so small "1/500 of the reserves of the top 9 inches of soil each year" that natural soil formation processes (pedogenesis), especially when speeded up by a biologically active soil, was more than sufficient to ensure that the fertility of soils were maintained or even increased. To be fair to Balfour, the type of farm to which this idea was primarily attached was the ley farming system (alternating grazed pasture with arable crops to feed the livestock) where only animal products were sold off the farm. However, it is clear from her writing and the positions of others promoting the closed system, especially in more recent times, that it is considered possible to have a productive farm that does not import nutrients in any form, e.g., fertiliser, compost, manure or feed, while at the same time exporting produce. This position is reflected in statements such as "To work, as far as possible, within a closed system with regard to organic matter and nutrient elements." From the IFOAM principle aims (that predate the current 'Principles of Organic Agriculture'), "To optimise nutrient cycles and prevent nutrient loss, you must return manure and plant wastes to the soil. You should return enough to increase or at least maintain soil fertility and microbial activity. Together with a sound rotation, this should form the basis of soil fertility management." and "Biological activity is responsible for soil fertility" both Soil Association.

1.2 Scientific Knowledge and Organic Agriculture

The above descriptions are considerable simplifications of what was a complex and detailed debate. However, in the first half of the 20th century the amount of scientific knowledge available to Howard, Balfour and other members of the debate was hundreds of orders of magnitude less than is available today. Many of the issues they could only speak of in poetic terms are now well understood and can be framed in precise technical descriptions and quantitative measurement. Science is increasingly in agreement with the fundamental arguments and concepts of organic agriculture, e.g., soil conditions unambiguously affect the quality of food, food quality clearly has an effect on human health and soil is a precious and limited resource that is currently being managed unsustainably. However, to avoid the charge of hypocrisy, if organic agriculture wishes to call on the authority of science to back up its position, it must also listen to and follow science when sufficient information and knowledge has accumulated to be able to decide on issues of debate or where lack of knowledge led the previous generations of organic proponents astray. This is not a radical suggestion, organic agriculture has made use of the scientific method since its earliest beginnings. Howard was a trained scientist and Balfour conducted 'The Haughley Experiment' which pioneered farm scale experiments. Therefore, this paper is also a call for organic agriculture to view this debate through the exceptionally solid foundation of accumulated scientific knowledge and end the 'Nutrient Schism'.

2. The Nature of Nature

The following explanation and discussions may at first appear an exceptionally long way removed, even irrelevant, to the debate over The Law of Return and Closed Cycles. However, it presents an inclusive and systematic overview of the scientific knowledge on which the debate rests, much, if not most, of which was not known at the time of the organic pioneers. Much of the knowledge is contemporary with the 'second wave' of the organic movement in the 1960s and it is thought unlikely to of been common knowledge among them. However, without such an understanding is not possible to fully comprehend the issue of nutrient management in agriculture.

2.1 Matter and Energy

The term 'nutrient' when used in relation to agriculture and food, refers to the chemical elements that are essential for plants and animals to live. The chemical elements are the fundamental parts from which all 'matter' i.e., the material of all physical objects, are composed and only composed.

Energy is the ability to 'do work', which may seem a rather prosaic and simplistic definition, but the science of energy and its transformation 'Thermodynamics' is one of the oldest sciences and has the highest level of certainty within scientific knowledge (it is as unassailable as scientific knowledge gets). Matter and energy are at a fundamental level the same thing, e.g., two sides of the same coin, as

discovered by Albert Einstein and defined in the equation $E = MC^2$ with E = energy, M = Matter and C = the speed of light (approx. 300,000 meters per second). Practically all of the energy transformations that occur in the conditions (e.g., temperature and pressures) that humans inhabit, i.e., as found on the earth, are not of Einstein's 'special relativity' but of thermodynamics, i.e., thermal and chemical processes involving only the electron shell of atoms and the exchange of photons. $E = MC^2$ refers to the energy of which matter is 'made' i.e., the energy released by processes such as that which power stars (including the sun) and the nuclear reactions harnessed by man, i.e., the nuclear in nuclear power refers to the atomic nucleus and the energy it is 'made of'. To illustrate, the chemical energy contained within a paper banknote (approx. 1 gram) contains around 16,000 joules of chemical energy while the atomic energy is approx. 90,000,000,000,000 joules.

Neither matter nor energy can be created or destroyed only transformed. Energy/matter was created in the big bang, i.e., the start of the universe, fourteen billion years ago, with the resultant matter being almost entirely hydrogen (H) and helium (He) (4:1). All the heavier elements have been formed since the big bang from the primordial H and He by nucleosynthesis in stars. The solar system including the earth formed 4.5 billion years ago, and is therefore built from the remains of several previous generations of stars, i.e., all the elements on earth heavier than H and He have been, and can only have been, formed within stars. The synthesis of elements (Appendix 1) up to and including iron produces energy and can be formed during the normal life of stars. Heavier elements require energy to synthesise them and therefore are only made at the end of a stars life when it explodes in a supernova (i.e., any gold or silver you are wearing (e.g., jewellery) was created in a supernova and nowhere else).

2.2 Matter, Energy and Planet Earth

The fundamental physics of matter and energy completely determine the functioning of life on the earth and everywhere in the universe.

For energy, the earth is an open system. It receives approx. 3.85×10^{24} joules per year of energy from the sun, mostly as visible light, on the daylight side of the planet, and ejects exactly the same amount from the night side of the planet as infrared light (heat). If the amounts were not exactly the same, the planet would increase in temperature. As context the energy captured by photosynthesis is 0.078% of incoming solar energy (3×10^{21} j/yr) while total human energy use is only 0.0057% of solar energy (2.2×10^{20} j/yr).

For matter, the earth is a closed system. There is a minuscule influx of matter from the solar system in the form of meteorites and related material, but the quantity is infinitesimal compared with the mass of the planet as a whole. Therefore, while energy constantly flows through the earth, via the biosphere and atmosphere, matter can only cycle within the planet. This situation is repeated for all the sub-systems that make up the biosphere including agriculture. Failure to maintain this pattern results in decreased biological functioning.

3. The Elements of Life

Of the 94 naturally occurring chemical elements (Appendix 1) nature has been rather conservative as plants use only 16 essential elements (hydrogen, oxygen, carbon, nitrogen, phosphorus, potassium, calcium, magnesium, sulphur, boron, chlorine, iron, manganese, zinc, copper and molybdenum) and five 'beneficial / optional elements' (nickel, silicon, sodium, cobalt, and selenium) with animals (depending on species) requiring a handful more. (From here on only plant, nutrients will be discussed for simplicity and because as plants are the first step on the 'food chain' / primary trophic level, the concepts equally apply to animal nutrients as well).

3.1 The Proportion of Life's Elements

The common conception of plant nutrients is of NPK (nitrogen, phosphorous and potassium), then Mg (magnesium) and the other micronutrients. However, all these nutrients combined only makeup approximately 4% of plant matter, with the rest being composed of carbon (C) 45%, oxygen (O) 45% and hydrogen (H) 6% (the proportions vary depending on the type of plant material (e.g., wood vs. leaves) and the units of measurement). The key reason C, O and H are not included in standard lists of plant

nutrients is because plants absorb them directly from the atmosphere and/or they are obtained from water (H₂O), absorbed from the soil. No action is normally required on the part of the farmer to replace such elements, as they are freely available and a lack of water results in crop death due to dehydration rather than a deficiency of H fertiliser. However, in some special circumstances, for example, within enclosed structures such as glasshouses, growers supply C as CO₂ as the plants can quickly use up all the available CO₂ within the structure and increasing CO₂ from atmospheric concentrations of 0.035% to around 0.09% results in increased yields, i.e., fertilizing plants with carbon increases crop growth just as it does any other fertiliser.

3.2 Absorbing Life's Elements

Why do these different nutrient uptake paths, i.e., leaves and roots, exist? The forms the elements occur in varies: some are gases, others as liquids or solids; these are the three 'states of matter'. Some occur in a more than one form, for example, H and O as water occurs in all three forms, others only exist in solid form although they can dissolve in water to become liquids. If a nutrient can never exist in a gaseous form, then it can only occur in the soil, not the atmosphere, so can only be taken up by plants via their roots. If a nutrient exists in multiple forms e.g., oxygen as the gasses O₂ and CO₂ and liquid i.e., water (H₂O) it can be absorbed by plants via both roots and leaves.

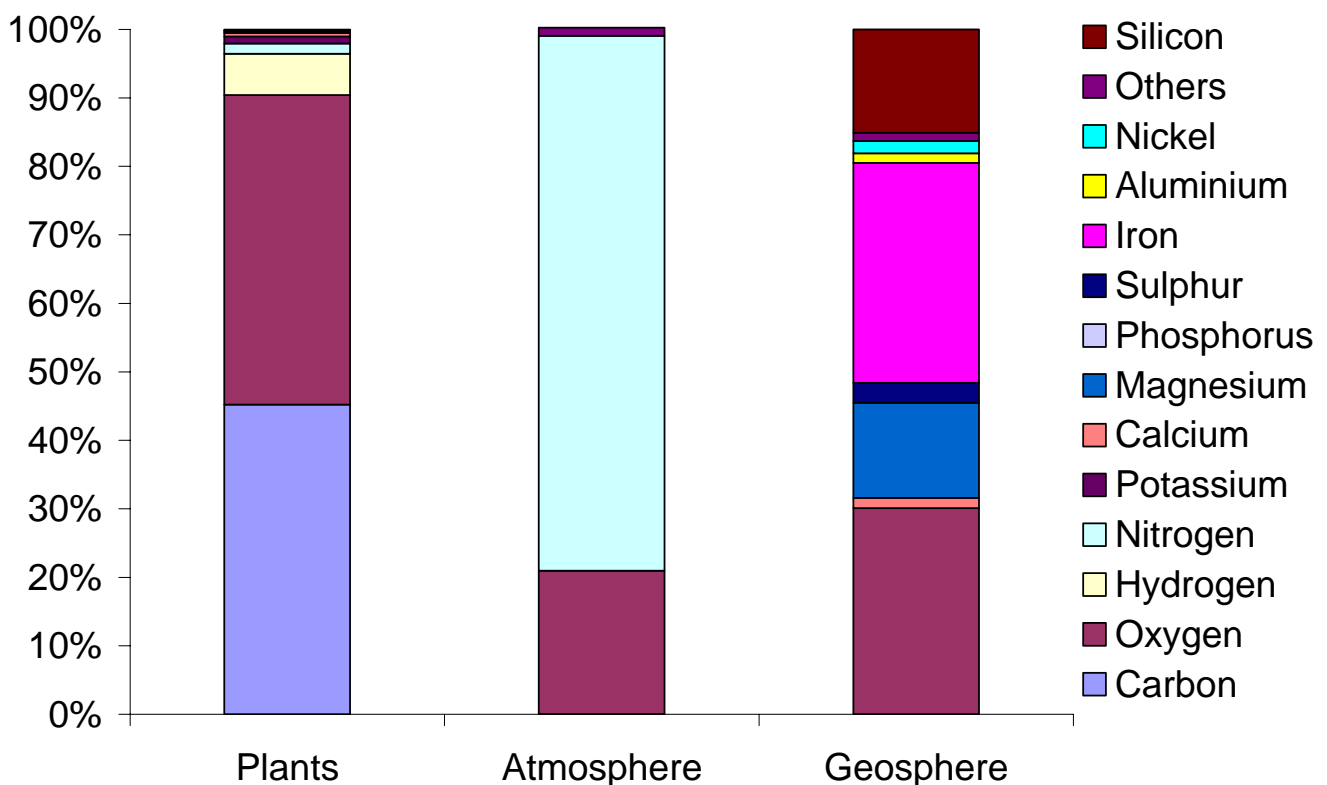

Figure 1. The relative proportions of the 'common' elements in plants, the atmosphere and the geosphere (The order of the elements for each column is identical to the key).

3.3 The Uneven Distribution of Elements

The ratio of elements within plants is dramatically different to the atmosphere, soil and the planet on which they live. Figure 1 shows the relative proportions of the common elements in plants, the atmosphere and the geosphere (the rocks, soil and water of the planet). It is clear there is hardly any commonality between all three. For example, carbon, which is considered the foundation element of life i.e., 'carbon based life form', is only 0.035% of the atmosphere and an almost vanishingly small proportion of the planet. The atmosphere consists of 78% N, 21% O, 1.2% chemically inert noble gasses and 0.035% CO₂ and nothing else. The geosphere consists of a range of metals, mostly in the form of oxides, e.g., silicon dioxide i.e., quartz. Therefore, while plants have been conservative about the number

of elements that they need, they accumulate and concentrate a small number, i.e., C, O and H at far greater concentrations than they exist in their surroundings.

3.4 Element Cycles

The states of matter that a nutrient occurs in also determine how it will cycle around the planet and farms as well as how plants can absorb them. These cycles are called the biogeochemical cycles, a contraction of biological - geological - chemical, which emphasises that the chemical elements move through both biotic ("bio-") and abiotic ("geo-") spheres. For example, if an element does not exist as a gas in either elemental or compound forms, then it is unable to cycle via the atmosphere as only gasses can cycle via the air. Although an unusual perspective for agriculture, considering how plant nutrients cycle through the biogeochemical cycles gives a holistic and complete description of the movements of plant nutrients on the planet, which is fundamental to understanding how plant nutrients behave at farm level.

3.4.1 The planetary spheres

Within the earth sciences the planet is organised into a number of 'spheres' referring to the different parts of the planet as (mostly) concentric spheres starting with the outer atmosphere down the centre of the earth. These spheres are fundamental units in the description of the biogeochemical cycles. There is no formally agreed definition and some terms, e.g., geosphere have changed over time. In this paper:

- the biosphere means all living things what ever their location;
- the atmosphere, refers to the air surrounding the solid part of the earth;
- the hydrosphere, all water on the earth, both fresh and salty;
- the geosphere, the solid parts of the earth, i.e., rocks, including soil but excluding the hydrosphere.

The geosphere is further divided up into:

- the pedosphere better know as soil;
- the lithosphere, the crust and upper mantle but excluding the soil.

4. The Biogeochemical Cycles of Plant and Animal Nutrients

The biogeochemical cycles are the earth's means of (re)cycling matter including the plant nutrients. If there were no biogeochemical cycles to move and mix planetary matter up then life of earth would be severely diminished as the nutrients of life are often those most easily lost from the biosphere to the depths of the lithosphere. Plate tectonics are therefore considered essential for a diverse biosphere. They are a primary measure of the likelihood of complex life on the other planets and moons of the solar system and extra-solar worlds. Therefore, there is a strong correlation between the fertility of the earth's soils and their age - with new soils being the most fertile and old soils the least.

4.1 The Timescale of Sustainability

The importance of specifying the timescale in relations to the biogeochemical cycle's effects on agriculture and the wider human impacts on nutrient management cannot be understated. Time is a fundamental part of the concept of sustainability, regardless of what is being sustained, e.g., a musical note, a farm, economics or a society. The sun has 'only' around five billion years before it 'dies', at which point life on earth will also die, which means that nothing on earth is sustainable as the earth is ultimately unsustainable. Therefore, when discussing sustainability, defining timescales is essential. In this paper the sustainability of nutrient cycles refers to human timescales i.e., years, to decades. These are the same timescales that the more general issue of environmental sustainability is framed in.

4.2 Biogeochemical Cycle Timescale

The speed of the biogeochemical cycles varies considerable depending which sphere a nutrient is moving through. Within the same sphere, the rate of movement of individual atoms is not fixed, i.e., they can

move at vastly different rates, therefore, the following times are averages. Further, there are considerable overlaps among the cycles and spheres so the following times are qualitative rather than quantitative.

The fastest is the atmosphere; the weather blows gasses around the planet, often at a considerable rate, while constantly mixing its constituents up, cycle times vary from seconds through decades to centuries. Next is the biosphere; living things are highly dynamic physical systems constantly taking in and excreting nutrients and energy. Cycle times are very similar to the atmosphere but slower on average. Third is the pedosphere / soil, which is the primary interface of the atmo- hydro-, geo- and bio-spheres and where land life starts and ends. Cycle times can be very quick, i.e., seconds but are often much slower taking years to centuries and longer. Fourth is the hydrosphere; the seas and oceans are as dynamic as the atmosphere, in fact the oceans are a fundamental part of the worlds climate, it is just that they move much more slowly and are less visible than the atmosphere simply because they are mostly liquid water and humans are air breathing creatures. Cycle times are rarely quicker than days and weeks to millennia are more common. In a clear last place is the geosphere, or more precisely the lithosphere, which moves far, far slower than a snails pace! A century is a geological blink-of-an-eye, with millennia rated as a sprint and millions of years far more typical of the timescale for rocks.

4.3 Human Timescale, Land-Based, Biogeochemical Cycles

The land-based, plant nutrient, biogeochemical cycles can be divided up into three ‘classes’ when viewed at human timescales:

- Those that (mostly) cycle through the atmosphere;
- Those that cycle equally through both the air (atmosphere) and soil (pedosphere);
- Those that only cycle through the soil.

It is critical to understand that the above are a special subset of the wider biogeochemical cycles. Plants and animals are the biosphere, i.e., all living things, and the matter / nutrients living things are made of cycle through both the biosphere and the wider abiotic (non-living) spheres, i.e., the atmo-, hydro and geo-spheres. This list therefore excludes all matter that does not cycle through the biosphere (because they are of no relevance to this discussion). The list is also constrained to the human timescale, which automatically eliminates the lithosphere. It also focuses on land-life, so the wider hydrosphere, i.e., the seas and oceans are not part of this subset.

4.3.1 How nutrients enter the biosphere

While there is no true start or end point in a cycle as it is a logical contradiction, there are key points where matter moves from one sphere to another which can be considered metaphorical starting points. For the biosphere, the starting point is plants. A plant in this context is anything that can photosynthesise, and it includes far more than the crops and trees that are normally considered as plants but also much smaller species all the way down to single-celled plants in the soil and seas. Indeed most of the world’s plant biomass is in the form of single celled plants. Plants form the basis of the ecological food chain, as they are the only living things that can capture the suns energy. Therefore, when discussing the intersection of the biosphere and abiotic spheres and the cycling of matter / nutrients among them, plants can be reasonably be considered to be the ‘start’. Crop plants, including pasture, are also the foundation of agriculture, as all agricultural products are ultimately derived from them.

Therefore, understanding which sphere plants obtain the elements of life from and how those nutrients move within the biosphere and between the biosphere and abiotic spheres is fundamental to understanding nutrient management in agriculture.

4.3.2 The (mostly) Atmospheric Cycles: Carbon and Oxygen

The nutrients that predominately cycle through the atmosphere are carbon and oxygen. The atmosphere contains 21% oxygen and 0.035% carbon dioxide (CO₂), both of which plants take in directly through their leaves. This is the only path by which C can enter a plant because plants cannot take up carbon via their roots as it does not exist in soluble form within the soil (except in miniscule amounts). Further photosynthesis by plants is the only route for C (as CO₂) to be removed from the atmosphere and moved

into the soil (as organic matter), i.e., there are no abiotic processes at human time scales that can transport atmospheric carbon into the soil, only photosynthesis in plants. The ‘reverse’ of photosynthesis is respiration whereby the solar energy trapped by plants in chemical form is released. Respiration also releases some of the nutrients tied up with the plant’s chemical energy. Carbon is one such nutrient and it is released as CO₂, which returns to the air completing the cycle. In addition, when the organic matter in the soil decomposes, i.e., is respired, the C is also released back to the atmosphere as CO₂.

Oxygen is more of a ‘loose player’, as it teams up with C to form CO₂ and H to form water (H₂O). Water is unique in many, many ways, including its behaviour within the biogeochemical cycles. It is the only chemical substance that naturally occurs as solid (ice), liquid (‘water’) and gas (clouds / water vapour) forms on earth at the same time. It is a planetary sphere in and of itself (hydrosphere) and although it is not technically considered part of the atmosphere, about 2-4% of the atmosphere is made up of water vapour. The hydrosphere also extends into the soil (pedosphere), so it is literally ‘water, water, everywhere’. Therefore oxygen can also enter plants as H₂O, mostly via the roots. Therefore, strictly speaking, O cycles through both the air and the soil.

The carbon, oxygen and hydrogen cycles are therefore intimately linked as O continually shuffles between C and H forming CO₂ and H₂O as part of the sublime duet of photosynthesis and respiration - biology’s greatest piece of (re)cycling Table 1.

Table 1. Photosynthesis and respiration

<p>Photosynthesis (controlled fuel manufacture) = CO₂ + H₂O + light energy → organic matter* + O₂</p> <p>Respiration (controlled burning) = organic matter* + O₂ → CO₂ + H₂O + chemical energy</p> <p>* organic matter is hydrocarbon e.g., C₆H₁₂O₆</p>
--

The rapid speed at which photosynthesis and respiration work means that while the soil contains about 50% of the carbon present in the soil, living things and the atmosphere combined (excluding hydro and geospheres) the most rapid turnover is between plants, animals and the atmosphere. Oxygen as carbon’s key chemical ‘partner’ in the cycle also cycles most rapidly through the atmosphere, while still passing through the soil at a more leisurely pace.

4.3.3 Air and Soil Cycles: Oxygen, Hydrogen and Nitrogen

As noted above O cycles through both air and soil, moving from the abiotic spheres to enter plants through both their leaves and roots. In comparison, H mostly enters plants via their roots, although it enters the soil from the atmosphere as rain and other forms of precipitation. This is because H, unlike O, is not found as a ‘free’ element as it is chemically reactive so very quickly bonds with other elements or chemicals, often the O in the air. A tiny amount of H gets into plants via the leaves as rain or water vapour but it is negligible and does not affect the fundamental fact that the water comes from the sky / atmosphere. Additionally, hydrogen also gets into plants as other chemical compounds e.g., ammonia (NH₃) via the roots. Again, this extra part of the H cycle makes no material difference to this discussion because the critical aspect is that H and O are intimately linked via their mutual product H₂O, which cycles from the oceans to the atmosphere and back down to the land and oceans as rain. While carbon may be the basis of life, water can be considered the heart of life: no water, no life, period.

Therefore, carbon oxygen and hydrogen, which between them make up 95% of plant matter, originate in the atmosphere as far as plants are ‘concerned’. This is why, despite them being by far the most important plant nutrients, they are hardly ever discussed as such, i.e., they are provided for free by the workings of the planetary spheres and cycles. From a practical agronomic and economically perspective this is incredibly important, because if these elements did not cycle via the atmosphere, i.e., they were only solid / soil nutrients, the weight of fertilisers applied would be the same as the weight of farm produce removed and therefore require an equal amount of effort to return them to farms. Further, if were C O and H were non-atmospheric nutrients and not replaced nutrient depletion would be extremely rapid.

Therefore understanding the difference between how C, O and H cycle and the rest of the nutrients is fundamental to understanding how soil nutrients must be managed. The first, and odd one out, is Nitrogen.

4.3.4 Nitrogen

Nitrogen is the 'odd' nutrient for many reasons. The first is that the main planet-wide reservoir is the atmosphere. For all the other nutrients (including C and O), over 99.9% is tied up in the rocks of the planet. For N 80% is present in the atmosphere, 20% in the rocks of the earth and just 0.004% in the soil, oceans 0.001% and living things 0.0002%. As a proportion of the atmosphere N is 78% (O 21% and CO₂ 0.035%) (Figure 1). Further compounding the oddness of N is that despite it being present in the atmosphere in far greater quantities than CO₂ and O, plants have not evolved a means to directly absorb N via their leaves. Were evolution a deliberate process this state of affairs could only be described as a rather major stuff-up! Part of the explanation for this strange situation is that unlike the O and CO₂ in the atmosphere, which can be directly used by plants in their chemical reactions, atmospheric N is 'un-reactive' i.e., it is chemically inert. This non-reactive nitrogen is called diatomic nitrogen (di-nitrogen) because it consists of two nitrogen atoms joined to each other and is symbolised as N₂. The process of turning N₂ into forms that plants can use is very difficult to achieve due to the strength of the bonds joining the two nitrogen atoms together, i.e., they are exceptionally difficult to break apart. This can only be accomplished by a small number of primitive bacterial by the process known as 'biological nitrogen fixation' and a few abiotic processes, mainly lightning where the immense pressures and temperatures of the lightning bolt provide the energy and extreme conditions required to break di-nitrogen's chemical bonds. These reactive forms of nitrogen are symbolised by 'Nr'. In the early years of the 20th century, Fritz Haber discovered how to turn atmospheric N₂ into Nr in the form of ammonia (NH₃). This process, called the Haber or the Haber-Bosch process, as Carl Bosch was instrumental in commercialising the process and both won Nobel Prizes for its discovery and implementation, requires temperatures of 550°C and pressures of 250 atmospheres / bar, an indication of how hard it is to break N₂ apart.

Until the advent of the Haber - Bosch process, the only form of N available to agriculture was via bacterial N fixation or natural deposition from abiotic processes such as lightning. In terms of practical manipulation of N fixation the only option was to grow crops, such as legumes, which have a symbiotic relationship with the Rhizobia bacteria, which live in nodules on the plants roots. The plants themselves cannot fix N₂ to Nr but they provide a home and food for the Rhizobia which in turn fix N and give it up to the plant. There are also free-living bacteria in the soil that are continuously fixing atmospheric N₂ into Nr, as well as a range of other microbes that are doing the exact reverse and turning Nr compounds into N₂, which is returned back to the atmosphere.

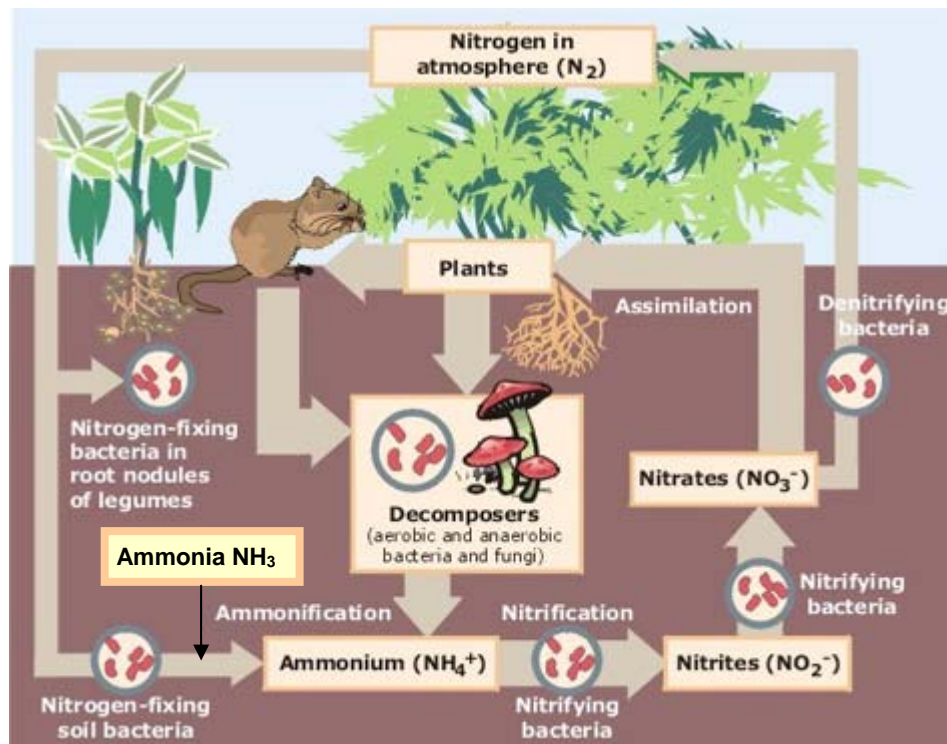

Figure 2. Highly simplified diagram of the nitrogen cycle through the soil, atmosphere and land biosphere (Source USDA).

To sum up, nitrogen is unique because most of it resides in the atmosphere as N_2 , which is of no use to living things except a few species of bacteria. These bacteria are responsible for its cycling from the atmosphere into the soil, where it can be taken up by plants or released back to the air by other microbes. Unfortunately, the N cycle is more complicated yet.

Most soil nutrients only come in a small number of different forms, which behave in a relatively straightforward manner within the soil. Nitrogen again stands out due to its highly complex pathways within the soil. Figure 2 shows a highly simplified diagram of the N cycle in the soil, atmosphere and land biosphere. A key point is how much this process is mediated by the biosphere: the majority of N_r in the soil and biosphere has been created by biological processes rather than abiotic processes.

4.3.5 The Soil Nutrients: P, K, Ca, Mg, S, Fe, Cl, Mn, Bo, Zn, Cu, Mo et al.

Compared with the complexity of N and to a lesser extent C, O and H, all the other nutrients cycles are pretty simple. Firstly, none of them exists in the atmosphere unlike N, C, O and H, so none of them can cycle via the atmosphere. This means they can only cycle via the geosphere / lithosphere and liquid and solid states of the hydrosphere, i.e., rivers, seas and oceans. This simplicity is however the undoing of the idea that organic agriculture does not need fertilisers.

As the 'non-atmospheric' / 'soil nutrients' cannot come from the atmosphere, the only place they can come from is the soil's parent material, i.e., the rocks from which the soil is formed. For example, if a nutrient is present in low levels in the parent rocks the soil will be deficient, and conversely if there is an 'excess' of a nutrient in the parent material it is likely the soil will contain excess, even toxic, amounts.

The formation of soil from the parent rocks is a slow process taking thousands of years. It initially starts as an abiotic physical and chemical process, which is accelerated by the biosphere once it gains a foothold, mainly due to the increased type and speed of chemical reactions. The biosphere also tends to concentrate the nutrients it needs, through the straightforward process that plants mostly absorb only the nutrients they require, so when they die and return the nutrients to the soil surface, those nutrients accumulate. This particularly applies to the 'atmospheric' nutrients which accumulate in soil at far higher concentrations that could be achieved had they only originated from the parent rock, i.e., plants 'pump' them out of the atmosphere and into the soil. The process of soil formation never stops but it is orders of magnitude slower than the continual and rapid cycling of nutrients from the soil into plants then into animals and back to the soil.

Figure 3 Shows a generalised schema of the behaviour of the non-atmospheric nutrients in soil.

Assuming that the soil is formed in-situ (e.g., its not deposited by rivers on an ongoing basis) the parent material / rocks very slowly release nutrients into the soil as signified by the single tiny arrow from the bottom oval. These nutrients are released as larger pieces of rock break down into smaller pieces, so for example, although there can be a 100 tonnes per hectare of potassium in a soil, most of it is in the form of rock and will not be available to plants for hundreds to thousands of years. Even as the parent rocks weather, the nutrients they release are not instantly available to plants. Many the nutrients move into other unavailable forms, for example, they can become incorporated within the lattice structure of clays where plants are unable to access them. The size of this nutrient pool is much smaller than the parent material but can still be substantial, for example for potassium the range is one to two tonnes per hectare. The longer-term inorganic nutrient pool is in a kind of balance with the much smaller pool of medium term inorganic and organic forms of nutrients, i.e., nutrients can move both ways from more available to less available forms, however, these are still unavailable to plants. The size of this pool is again considerably smaller than the previous pools, continuing the K example, 50 to 100 kilograms per hectare. Finally, there is the soil-solution nutrient-pool. Plants can only take up nutrients in soluble inorganic forms (with a few minuscule exceptions) so this is the only nutrient pool that plants can draw on, but it is very small, for K it is typically 5 to 20 kg /ha and for phosphorous it can be only a few hundred grams per hectare! Fortunately the rate of exchange between the soluble pool and the medium term pool is the fastest of all the exchanges, but it is not infinite - if plants remove nutrients faster than they can be replaced from the medium and longer term pools then the available nutrient pool can shrink to the point that plants cannot get enough and become deficient, even though there are more than enough nutrients in the soil as a whole.

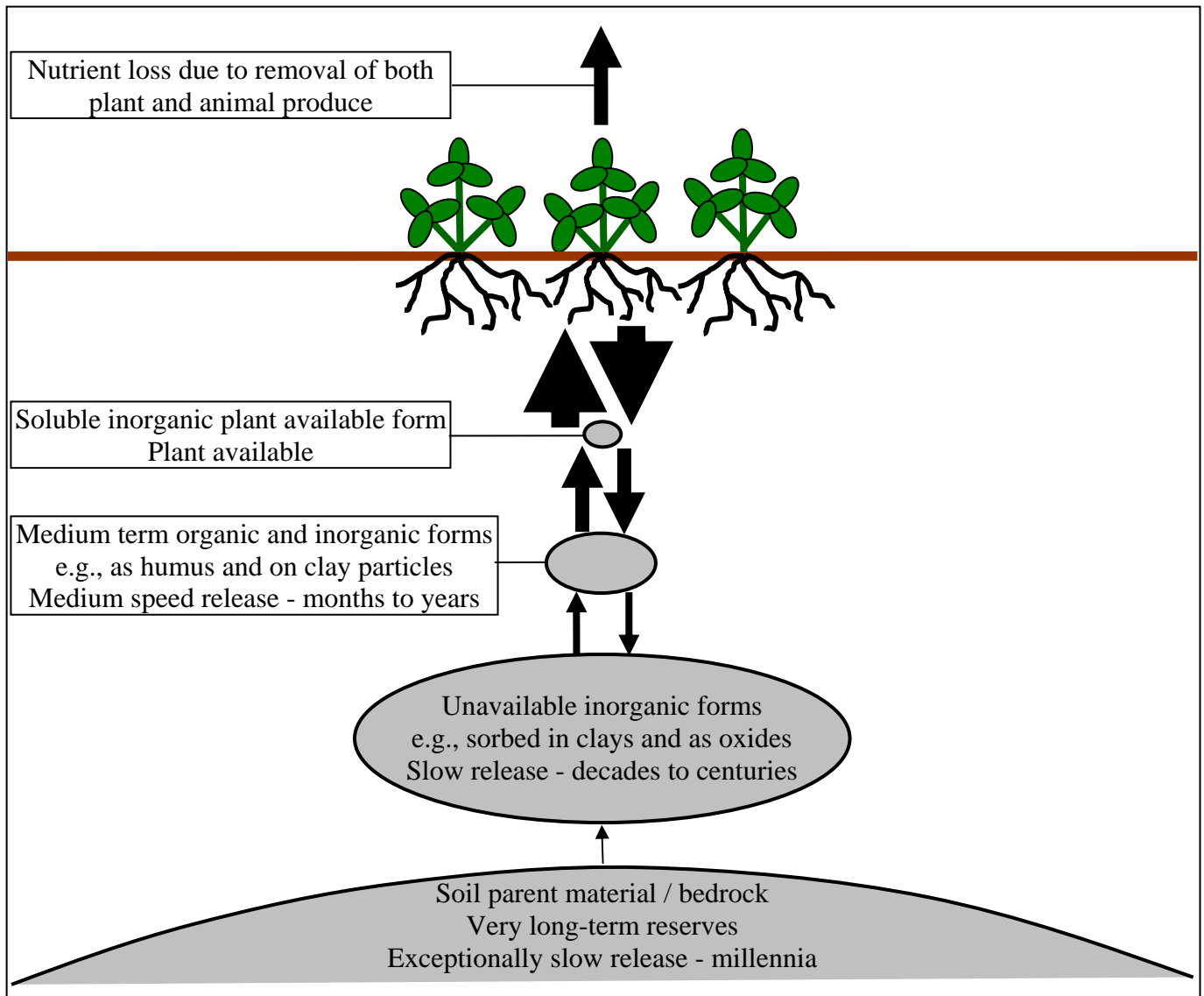

Figure 3. Highly generalised schema of the behaviours in soil of the non-atmospheric / soil plant nutrients. The ovals represent the size of each nutrient pool while the arrows indicate the speed, size and direction of nutrient flows among the pools.

4.4 Fertiliser Type and Soil Health

N.B. this paper deliberately ignores the issue of the effects of different forms of fertilisers, e.g., synthetic fertilisers vs. compost, on soil function / biology and the effect on the ecological food chain of plants and animals. While, there is considerable evidence, indeed, it is almost self evident, that different forms of fertiliser will produce different effects on soil biology and that this can have an effect on plant and animal health, such issues are outside this paper's topic and scope.

5. Why soil nutrients have to be replaced

We are now in a position to understand why the Closed System proponents including Balfour's belief that "In terms of removal from the soil, this works out to infinitesimal amounts of mineral substances (at the most 1/500 of the reserves of the top 9 inches of soil each year)" and therefore nutrients do not have to be replaced and the whole Closed System concept, fails.

5.1 Nutrients: Wrong by Degree

While the amount of nutrients removed in produce is small compared with the amount in the soil, (1/500 is small but far from infinitesimal) it is a considerable proportion of the amount of plant available nutrients and a sizeable fraction of the medium term pools. Very simply, if nutrients in produce are

removed faster than the conversion rate of parent rock into the smaller pools, they will eventually shrink to the point that the soil is unable to supply sufficient nutrients to plants and they become deficient. A fundamental mistake of the Closed System approach was to believe that all the nutrients in a soil are equally available when they are not. This is not a slur on their abilities, rather a reflection of knowledge at the time: indeed, it was in the Hawley Experiment that it was first noticed that nutrient availability varied over the seasons - a matter of considerable surprise to the experimentalists and the wider soil science community of the time. Another way to conceptualise the situation, is to think of the soil, excluding the parent material, as a bucket (after Liebig's barrel) containing the exchangeable nutrient pools Figure 4.

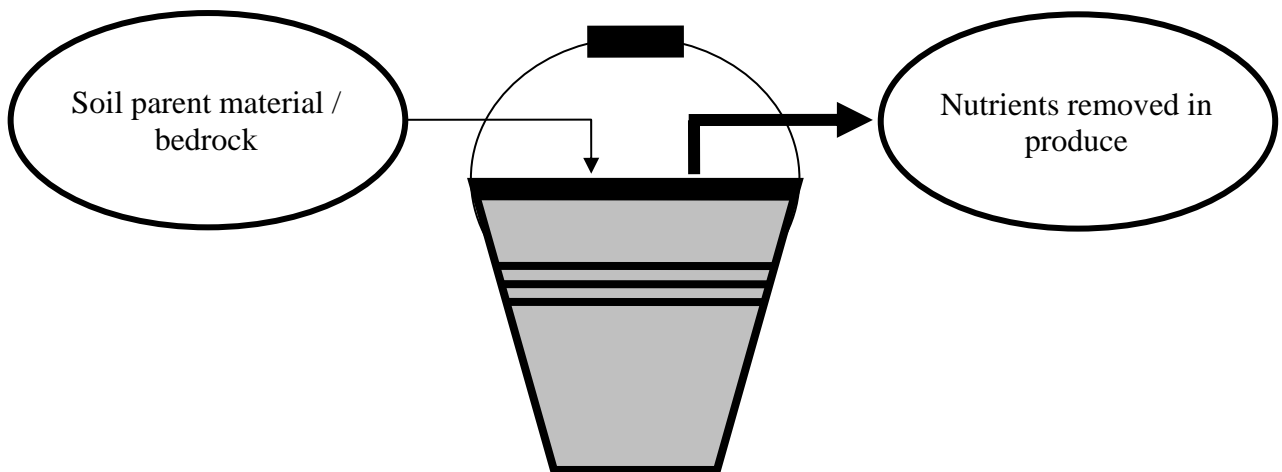

Figure 4. The 'soil nutrient bucket' demonstrating that if nutrient inflows from the parent material are smaller than nutrient outflows (in produce) then eventually the bucket will empty and from that point forward nutrient removal cannot exceed nutrient input due to logical necessity.

The bucket represents the fact that the soil (as far as the soil nutrients are 'concerned') has clearly defined boundaries through which nutrients pass in and out. If the amount going into the bucket is smaller than the amount being removed, then the bucket will at some point become empty and from then on it will be logically impossible to remove more nutrients than are entering.

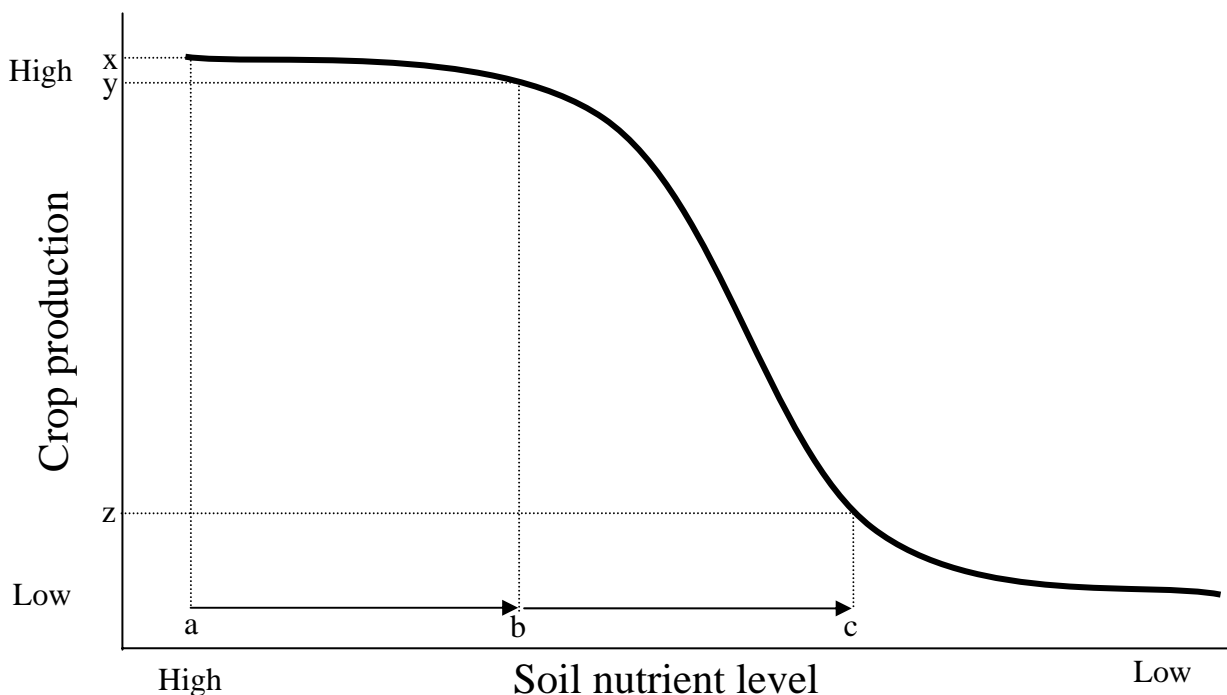

Figure 5. Illustrative sigmoid (S shaped) curve of the relationship between soil nutrient level and crop production.

The actual situation is slightly more complicated than the bucket metaphor indicates because the relationship between soil nutrient levels and plant growth is not linear. Figure 5 shows the sigmoid relationship between soil nutrient level and crop production. When soil nutrient levels are high (point a) crop production is also high (x). If soil nutrient levels are sufficiently high, then they can reduce considerably (from a to b) with only a tiny effect on crop production (the reduction from x to y). However, if nutrient levels continue to drop, the central part of the curve is encountered where small changes in soil nutrient status result in large changes in crop production, i.e., a drop in nutrient levels from b to c of exactly the same size as from a to b results in a very large reduction in crop production from y to z.

Due to the small but continual supply of nutrients from the parent rock of the soil, production rarely ever reaches zero, i.e., the bucket is effectively empty except for a trickle of nutrients in and a trickle out (i.e., very low yielding, nutrient deficient crops). The effect predicted by graph in Figure 5 is exactly what is found in real-world farming practice. When farms stop applying fertilisers often little change is seen in yields for several years even decades (the change due to nutrient levels is often much smaller than the year to year variation due to weather and other factors so is very hard to discern). However, after sufficient time production starts to drop, and then often plunges. This is the actual experience, in Ireland, on organic farms that stop applying fertiliser when they convert. All is well for about six or so years as the 'fat of the land' is used up, then production plummets as the farm's 'muscles' start wasting away. The same goes for all long-term agricultural trials studying the effects of lack of nutrient replacement. Often there are no changes for several years, and on exceptionally deep and fertile soils, decades, however, at some point production and quality plunge then level off at very low levels. To completely press the point home, this happened in Ireland as a whole prior to the introduction of fertilisers, as plant and animal produce had been continually removed from the land for many generations without replacement, resulting in widespread soil nutrient depletion and miserable yields of crops and sick animals. Where the opposite is the case, all nutrients removed in produce are returned, e.g., as manure, then soil fertility can slowly increase due to the slow release from the parent rock adding to soil nutrients. Within the organic movement the 'favourite' exemplar of this (including by Howard) is the 'ancient Chinese' agricultural systems that continued for thousands of years due to the return of all nutrients back to the land, including human manure.

However, while the Closed System proponents including Balfour were incorrect regarding the replenishment of nutrients, it was as more by degree than by kind. If the size of the flows in Figure 4 are reversed, i.e., more nutrients enter the bucket than leave it, the bucket will fill up, but unlike a bucket the total nutrient levels within a soil can keep growing. This is no radical idea, rather it is simply a restatement of how soils form. As described above, plants accumulate the nutrients they need, so these accumulate in the top soil. If there is a continual nutrient input from parent rocks which is greater than losses via crop removal or natural losses such as erosion, then the total amount of nutrients in the soil can increase, and the total amount of soil can also increase, i.e., get deeper, as rock turns to soil, not forgetting that this process that takes millennia, i.e., much slower than human timescales.

For farm systems, this means there is a very simple formula for soil nutrient management - that the difference between the amount of nutrients removed in produce and that supplied by the weathering of the parent material must be returned to the soil to keep nutrient levels static. As the amounts removed in animals and particularly crops, (the annual yield of which per hectare can be order of magnitude greater than animal products so nutrient removal is greater by the same degree) is far, far greater than the input from rock weathering, for practical purposes nutrient supply from parent rocks can be ignored at human time scales.

5.2 Suggested alternatives and why they are wrong

As the scientific understanding of soil processes has increased, the Closed System concept has become increasingly shaky. As the evidence has stacked up against the Closed System, a range of alternative sources of nutrients have been suggested as a means to prop-up the theory. While the following may appear far-fetched as a 'way out', it has been personally suggested to me in all seriousness by farmers and other members of the organic community.

The creation and transmutation of elements including by radioactive (atomic) decay have been suggested. However, the fundamental physics of the chemical elements (as outlined at the start of this paper) prohibits such sources. Elements cannot be created - only transformed from other elements and/or energy. The temperatures and pressures required to achieve such transformations only exist in stars and nuclear fission and fusion reactors built by humans; therefore such processes are impossible in soils. Radioactive decay cannot be a source of nutrients. First it is far too slow, for example potassium decays to argon, but very slowly with a half-life of 1,260,000,000 years (the universe is only 14,000,000,000 years old). Were it to occur at rates sufficient to replace the quantities of nutrients removed in produce, then the soil would be so radioactive that it would be inhospitable for life. In addition, elements generally decay into the element one place lower than themselves on the periodic table (Appendix 1) and many of the plant nutrients are clustered together in the table so an increase in one can only come at the expense of another.

Simply put, matter cannot be created or transformed in the conditions found in agriculture, if matter is removed from a farm, it simply must be replaced.

5.3 Closed Farm System: Wrong by Kind

While the Closed System proponents were wrong more by degree than kind, when it came to nutrients being released from parent rocks at sufficient rates to replace off takes in farm produce, they were wrong by kind rather than degree when it came to their concept of the farm as a closed system. The origin of the word 'organic' is not organic matter as is widely, but mistakenly believed, but a contraction of 'organism'. Some of the organic pioneers used the concept / metaphor of the farm as an organism, i.e., a whole that is also a collection of wholes, or holons to use the term coined by Arthur Koestler. The farm as an organism was believed to be self-contained, i.e., a closed system. While this is a considerable simplification of the argument (for the sake of brevity), it is now very clear that farms are not closed systems for anything.

Farms are not wholes they are holons, i.e., parts of greater wholes, such as ecosystems, countries and all the way up to the ultimate whole, the biosphere to which James Lovelock gave the name Gaia. As the biosphere is the ultimate whole, all other parts of the biosphere must therefore be holons, including farms. The key feature of holons is they constantly exchange matter and energy with their wider environment / larger holons they are part of, i.e., they are open systems, not closed.

The earth is not a closed system for energy, as described at the start of this paper. Energy floods through the planet in literally astronomical quantities. Farms are also just as open to energy as the earth is. Further 96% or so percent of plant nutrients (the atmospheric nutrients, C, O, H and N) come from outside the farms boundaries (the atmosphere), i.e., they are imported, and are eventually returned there. Even soil nutrients are lost from natural systems at slow rates via leaching and erosion, and farming, even pre-industrial, has always accelerated these natural rates of loss. Even without human intervention, soils wear out. As described at the start productive soils are the youngest soils, and the most productive are those that are replenished annually by floods. Most of the earth's surface is continually replaced over periods of tens to hundreds of millions of years by plate tectonics. Those soils that escape this process become so denuded that they can only support the most meagre vegetation, i.e., even completely natural systems, without human intervention, can result in depleted soils. If nature can destroy soils through the geologically slow process of leaching then humanity can do the same, but much faster, by failing to obey the Law of Return.

To summaries: the whole concept of the farm as a closed system is incorrect. Both matter and energy constantly flow and cycle through its boundaries in large quantities, and even the soil nutrients enter and leave without human intervention and exit far more rapidly with human assistance.

6. The solution

6.1 Close the soil nutrient cycles

The fundamental solution is conceptually very simple: close the nutrient cycles in human time scales and return the nutrients removed from the soil in produce back to the soil as fertiliser. Practically the solution

is far, far more complex. Prior to the industrial revolution most food was produced and consumed locally so closing nutrient cycles was practically simple - just return human manure back to the fields. The industrial revolution created urbanisation, which resulted in food being traded, i.e., moved from the countryside to the new urban centres. However, the nutrients in the food were rarely returned, most of it (as sewerage) was dumped into the rivers and from there to the seas and oceans. This created two problems, the eutrophication of the waterways and the removal of nutrients from farm soils at human time scales. By putting the nutrients into the rivers, they moved from the pedosphere and land biosphere, into the hydrosphere which at human time scales is a one way trip, i.e., not a cycle, because as soil nutrients cannot be cycled via the atmosphere, they cannot escape the hydrosphere via the air, the only exit from the hydrosphere is the lithosphere, i.e., the rocks of the planet. As described above these are still cycles, but the timescale moves from the human time scales of years and decades to millions even hundreds of millions of years. This is a very serious problem because the human species is only 200,000 years old, agriculture around 10,000 years and the industrial agricultural system around 200 years old, i.e., humanity is dramatically accelerating a small part of the global nutrient cycles on which it is utterly dependent, i.e., from the pedosphere (farms) to the hydrosphere (oceans) from where there is no known effective, practical or economic means of retrieving them in the required quantities at human time scales.

6.2 The history of the solution

The awareness of this situation is not new, in fact it was realised soon after the start of the industrial revolution. Karl Marx writing around 1850 (70 years before Howard) said that “Capitalist production ... disturbs the metabolic interaction between man and the earth, i.e. it prevents the return to the soil of its constituent elements consumed by man in the form of food and clothing; hence it hinders the operation of the eternal natural condition for the fertility of the soil...”^[1] Marx was no soil scientist or ecologist, indeed Marx’s writing precedes the full emergence of these sciences by fifty and a hundred years. He was only repackaging the views of others working decades before him. However, farmers did not need the likes of Marx to realise they had a problem, the decline in soil fertility was evident to their own eyes, even if their understanding of the reasons was virtually nil: ‘soil sickness’ was about as good an explanation as was possible. Most farmers realised the solution was to use the well-known fertiliser effect of animal and human manures, and they were keen to import fertilisers such as manures and pulverised bones, to fertilise their soils. The problem was they were in very short supply, for example “The value of bone imports to Britain increased from [pounds]14,400 in 1823 to [pounds]254,600 in 1837. ... So desperate were European farmers in this period that they raided the Napoleonic battlefields (Waterloo, Austerlitz) for bones to spread over their fields.”^[1]

The first temporary relief came in the form of guano - i.e., the accumulated droppings of sea birds, which is one of the rare, and truly infinitesimal, human timescale return circuits from the hydrosphere to the land. Guano contains a full compliment of plant nutrients, so it proved to be an excellent fertiliser. Indeed, it was so effective it created “guano imperialism”...

The “United States undertook - first unofficially and then as part of a deliberate state policy - the imperial annexation of any islands thought to be rich in this natural fertilizer. Under the authority of what became the Guano Island Act, passed by Congress in 1856, U.S. capitalists seized ninety-four islands, rocks, and keys around the globe between 1856 and 1903, sixty-six of which were officially recognized by the Department of State as U.S. appurtenances. Nine of these guano islands remain U.S. possessions today.”^[1]

However, guano proved to be a finite resource because, although it accumulated each year when the sea birds bred, the rate of removal far exceeded the rate of replenishment. As guano ran out alternatives were needed, and were found, pretty much in the nick of time, in the form of underground reserves of nitrate, potassium and phosphorous ‘rocks’.

At the time, these reserves also seemed inexhaustible / infinite. However, today the lifetime of these fossil nutrient reserves are increasingly well established and their origins are fully understood. They mostly originate from large shallow seas, tens to hundreds of millions of years ago where nutrients such

¹ Foster, John Bellamy, and Fred Magdoff (1998). "Liebig, Marx, and the Depletion of Soil Fertility: Relevance for Today's Agriculture." *Monthly Review*. 50: 32-45.

as N, P and K accumulated after being washed from the land and then trapped as the sun evaporated the water, as is happening in the Dead Sea today. These seas and their nutrient rich sediments were then buried by further sediments and uplifted by tectonic activity to their current positions, i.e., these are nutrients concentrated by unusual conditions but that are proceeding through the normal multi-million year geosphere stage of the planetary nutrient cycles. Humans have found a way to short circuit part of the geocycle by mining these nutrients. However, just like fossil fuels and guano, which appeared vast and inexhaustible, they are relatively small, and, just like fossil fuels and guano they have a 'peak' of maximum extraction, after which production can only decline. The current estimated reserves of phosphorous are around 70 years and there are some three to four centuries of potassium remaining. While humans have been able to short circuit part of these nutrients geocycles, it is only a very small part. The fundamental problem remains: that humanity is removing soil nutrients from the soil and into the hydrosphere from where the only natural means of return is via the lithosphere.

A comparison with the current 'energy crisis' is valuable at this point. Most of the energy that has, and continues to power the industrial revolution has been fossil energy in the form of fossil fuels such as coal and oil. 'Peak oil' and 'peak coal' are not fundamental physical problems. The amount of energy that flows through the planet compared to what humanity uses is truly vast, in addition to the figures given earlier in this paper, the amount of solar energy reaching the surface of the planet is so immense that in one year it is approximately twice that will ever be obtained from all of the Earth's non-renewable resources of coal, oil, natural gas, and mined uranium combined ^[2]. While there are no 'economic substitutes' for energy, there are plenty of economic substitutes for fossil fuels as energy sources, i.e., renewable energies that directly (e.g., solar panels) or indirectly (e.g., wind and wave power) harness the energy from the sun. However, not only are there no economic substitutes for the chemical elements, including the plant nutrients, there are no economic substitute sources of plant nutrients left. When they have run out, that is it. The only option at that point is to (re)cycle the soil nutrients from the soil, through society and back to the soil at human time scales.

One of the 'side effects' of using fossil fuels is climate change. The Stern Review on the Economics of Climate Change said, "Climate change is the biggest market failure the world has ever seen". There is no comparison of the many orders of magnitude greater threat that climate change presents to humanity compared to dwindling supplies of fossil nutrients. However, Humanity has understood the nutrient depletion of the soil, at some conceptual level, since the inception of agriculture some 10,000 ago. Humanity started climate change only about 200 years ago and discovered it around 30 years ago. If a problem discovered only 30 years ago is the biggest market failure the world has ever seen, then a problem perceived since the dawn of agriculture, that has been well understood for 200 years including the solution, and which has been to the brink of exhaustion twice before, should be described as...?

7. The End of the Schism

As described at the start of this paper, the practice of organic agriculture is based on scientific knowledge, i.e., as opposed to belief, although the use of science is guided by clearly defined ethics and a deep understanding of the limits of science (e.g., see³). It was also noted how limited the scientific information available to the organic pioneers and even the founders of the organic production standards in the 1960s and 1970s. Most of the scientific knowledge presented in this paper has been discovered, or at least become widely known, since the pioneers time and significant amounts since the fundamental content and structure of standards were created. For example in the 1920s there were 72 known elements, we now know there are 94 naturally occurring ones. In the 1920s, the understanding of the elements was at a mostly empirical, chemical, level. The advent of Einstein's relativity and the understanding of the sub-atomic quantum 'worlds' it helped lay the foundations for, now mean humanity has a fully complete theoretical understanding of the chemical elements at a fundamental physical level (the same as we now have a complete understanding of gravity and space-time). As further illustration, the science of chemistry has its foundations in alchemy (which was practiced by Isaac Newton 1643 - 1727) one aim of which was to find the philosophers stone that could turn base metals into gold. Based on the quantum

² <http://gcep.stanford.edu/research/exergycharts.html>

³ Barrow J.D. (1999) *Impossibility: The limits of sciences and the science of limits*. Vintage, London.

mechanics, humanity has made a further 22 elements that never have, and never will, exist in nature. The ability to transform elements into each other, and elements into energy and energy back into matter is now routine, making the idea of the philosopher's stone look exceptionally quaint. The origin of the universe, stellar nucleosynthesis, nuclear fusion, fission and radioactivity, plate tectonics and biogeochemical cycles, on which this analysis relies, all postdate, or are highly unlikely to be known by the organic pioneers such as Howard and Balfour and many members of the organic movement since their times.

There is a point when the level of scientific knowledge is such that it is able to act as a final arbiter. I would like to humbly suggest that in terms of the schism in organic agriculture between the Law of Return and Closed Cycles that the case is now closed and that Howards Law of Return has prevailed.

Appendix 1. The periodic table of the naturally occurring chemical elements

1 Hydrogen H																	2 Helium He	
3 Lithium Li	4 Beryllium Be											5 Boron B	6 Carbon C	7 Nitrogen N	8 Oxygen O	9 Fluorine F	10 Neon Ne	
11 Sodium Na	12 Magnesium Mg											13 Aluminium Al	14 Silicon Si	15 Phosphorous P	16 Sulphur S	17 Chlorine Cl	18 Argon Ar	
19 Potassium K	20 Calcium Ca	21 Scandium Sc	22 Titanium Ti	23 Vanadium V	24 Chromium Cr	25 Manganese Mn	26 Iron Fe	27 Cobalt Co	28 Nickel Ni	29 Copper Cu	30 Zinc Zn	31 Gallium Ga	32 Germanium Ge	33 Arsenic As	34 Selenium Se	35 Bromine Br	36 Krypton Kr	
37 Rubidium Rb	38 Strontium Sr	39 Yttrium Y	40 Zirconium Zr	41 Niobium Nb	42 Molybdenum Mo	43 Technetium Tc	44 Ruthenium Ru	45 Rhodium Rh	46 Palladium Pd	47 Silver Ag	48 Cadmium Cd	49 Indium In	50 Tin Sn	51 Antimony Sb	52 Tellurium Te	53 Iodine I	54 Xenon Xe	
55 Caesium Cs	56 Barium Ba	57-70	71 Lutetium Lu	72 Hafnium Hf	73 Tantalum Ta	74 Tungsten W	75 Rhenium Re	76 Osmium Os	77 Iridium Ir	78 Platinum Pt	79 Gold Au	80 Mercury Hg	81 Thallium Tl	82 Lead Pb	83 Bismuth Bi	84 Polonium Po	85 Astatine X	86 Radon X
87 Francium Fr	88 Radium Ra	89 Actinium Ac	90 Thorium Th	91 Protactinium Pa	92 Uranium U	93 Neptunium Np	94 Plutonium Pu											
		57 Lanthanum La	58 Cerium Ce	59 Praseodymium Pr	60 Neodymium Nd	61 Promethium Pm	62 Samarium Sm	63 Europium Eu	64 Gadolinium Gd	65 Terbium Tb	66 Dysprosium Dy	67 Holmium Ho	68 Erbium Er	69 Thulium Tm	70 Ytterbium Yb			

The essential plant nutrients / elements are highlighted by the thick cell border. The non-essential nutrients are nickel, silicon, sodium, cobalt, and selenium.